

---

# **FnIO G – Series**

## **GT-7641**

**GT-7641 (Field Power Distribution 5Vdc, 24Vdc, 48Vdc, 110Vac,  
220Vac, ID Type)**

# Specification

---

## Table of Contents

Table of Contents.....	2
History.....	3
1.Environment Specification.....	4
2.GT-7641(FieldPower Distribution 24Vdc, ID Type).....	5
2.1.GT-7641 Specification.....	5
2.2.GT-7641 Wiring Diagram.....	6
2.3.GT-7641 LED Indicator.....	7
2.3.1.LED Indicator.....	7
2.3.2.Status LED.....	7
2.4.Example.....	8

---

## History

REV.	PAGES	REMARKS	DATE	Editor
Rev 1.00			Aug 22, 2016	HS KIM

# Specification

## 1. Environment Specification

<b>Environmental Specification</b>	
Operation Temperature	-40°C ~ 70°C
UL Temperature	-20°C ~ 60°C
Non-Operating Temperature	-40°C ~ 85°C
Relative Humidity	5% ~ 90% Non-condensing
Mounting	DIN rail
<b>General Specification</b>	
Shock Operating	IEC 60068-2-27
Vibration Resistance	Based on IEC 60068-2-6 Sine Vibration <ul style="list-style-type: none"> <li>- 5 ~ 25Hz : ±1.6mm</li> <li>- 25 ~ 300Hz : 4g</li> <li>- Sweep Rate : 1 Oct/min, 20 cycles</li> </ul> Random Vibration <ul style="list-style-type: none"> <li>- 10 ~ 40 Hz : 0.0125 g<sup>2</sup>/Hz</li> <li>- 40 ~ 100 Hz : 0.0125 → 0.002 g<sup>2</sup>/Hz</li> <li>- 100 ~ 500 Hz : 0.002 g<sup>2</sup>/Hz</li> <li>- 500 ~ 2000 Hz : 0.002 → 1.3 x 10<sup>-4</sup>g<sup>2</sup>/Hz</li> <li>- Test time : 1hrs for each test</li> </ul>
Industrial Emissions	EN61000-6-4/All : 2011
Industrial Immunity	EN 61000-6-2 : 2005
Installation Position	Vertical and horizontal installation is available
Product Certifications	CE, UL

# Specification

## 2. GT-7641 (Field Power Distribution 24Vdc, ID Type)

### 2.1. GT-7641 Specification

Items	Specification
<b>Technical Data</b>	
Field Power Voltage	Norminal 24Vdc
Field Power Contacts Current	Max. 10A Operating Temperature -40°C~50°C : Max. 10A 50°C~70°C : Max. 7A
Indicator	1 Green LEDs 1 Green Internal Bus State
<b>General Specification</b>	
System Power Dissipation	Max. 30mA @ 5Vdc
Wiring	I/O Cable Max. 2.0mm <sup>2</sup> (AWG 14)
Weight	70g Max.
Module Size	12mm x 99mm x 70mm
Environment Condition	Refer to '1. Environment Specification'

# Specification

## 2.2. GT-7641 Wiring Diagram

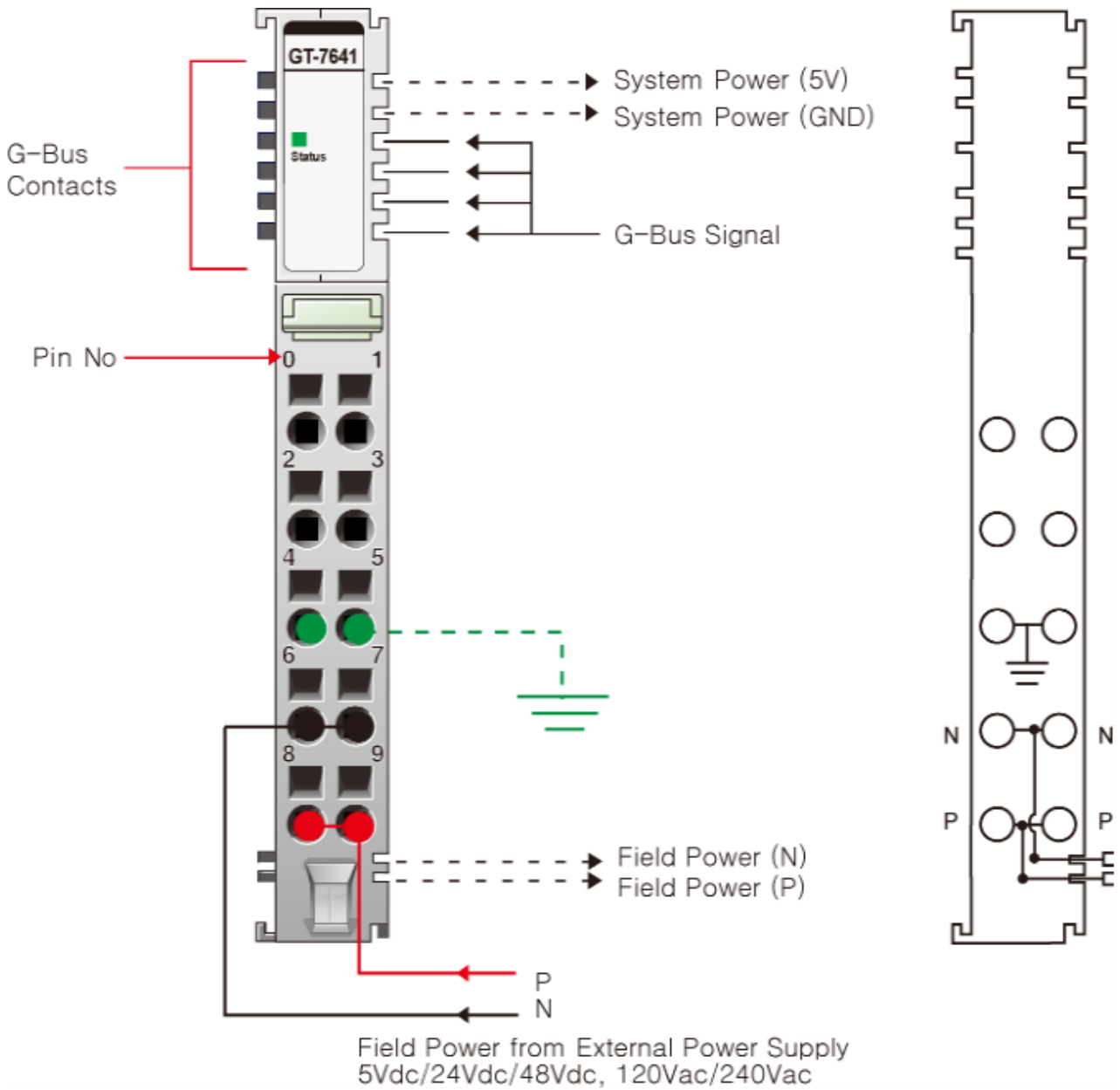

Pin No.	Signal Description	Signal Description	Pin No.
0	NC	NC	1
2	NC	NC	3
4	F.G	F.G	5
6	Field Power, Arbitrary (N)	Field Power, Arbitrary (N)	7
8	Field Power, Arbitrary (P)	Field Power, Arbitrary (P)	9

# Specification

## 2.3. GT-7641 LED Indicator

### LED Indicator

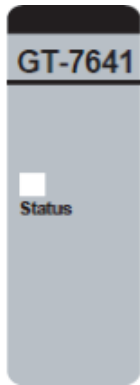

2.3.1. LED No.	LED Function / Description	LED Color
Status	Internal Bus Status	Green

### 2.3.2. Status LED

Status	LED	To indicate
Normal signal.	Green	The unit is operating in normal condition. ( After normal initialization of GBUS communication, this LED maintains ON status.)
Absence of network adapter	Off	Network adapter is not connected to this module.

# Specification

## 2.4. Example

The GT-7641 provides Field Power

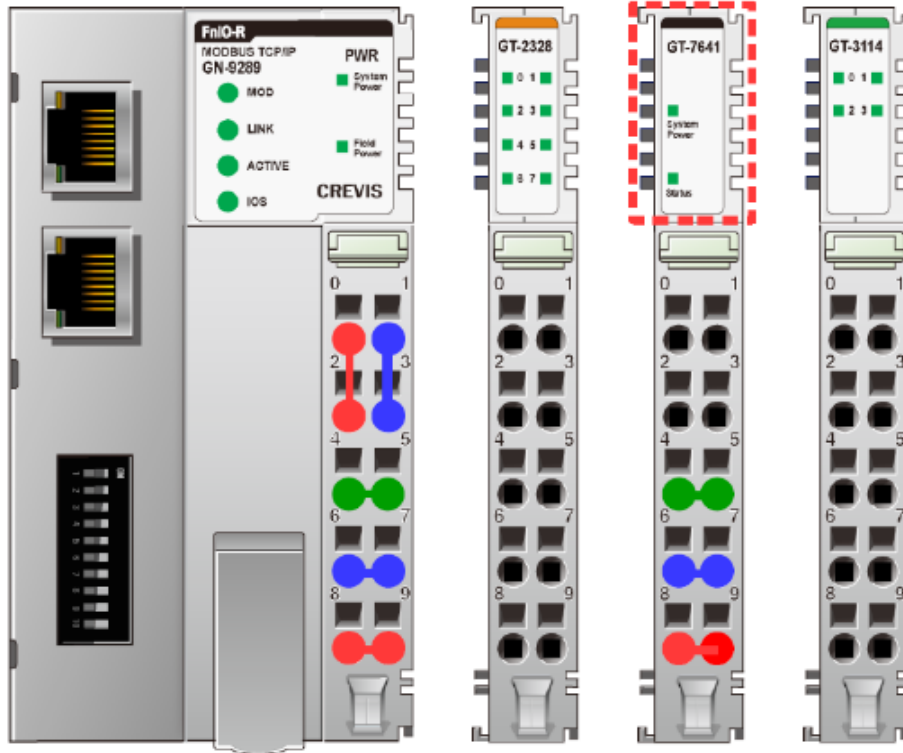

Color	System Power	Field Power
<span style="color: red;">█</span>		
Hole Number	0, 2	8, 9
<span style="color: blue;">█</span>		
Hole Number	1, 3	6, 7
<span style="color: green;">█</span>	4, 5 (F.G)	
Hole Number		